

Orange County
Model A Ford Club

THE DISTRIBUTOR

56 Years



Volume 58, Issue 4

April, 2018

Editor Tissy Smith-Hatcher

My best friend
is the one who
brings out the
best in me.

Henry Ford

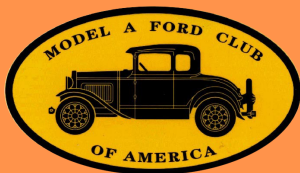

Inside this issue:

| | |
|---|----|
| MAFCA Application | 2 |
| Tours & Activities/ Calendar/Swap Meets | 3 |
| Board Member Contact Info General Meeting Minutes | 5 |
| New Members & Changes/The New Ford Roadster | 6 |
| What You Missed/ Build a Distributor Workstand/MAFCA's Blue Oval Program | 7 |
| The Reminiscences of Mr. Harold Hick (Part 1) | 8 |
| Leaking Cork Seal/ What Do You Think? | 9 |
| Trivia | 10 |
| In Memoriam/ Sunshine & Sorrow | 11 |

Hooray, the Pancake Breakfast
is finally here!!



HAVE WE GOT A DEAL FOR YOU!!

The Model A Ford Club of America is offering a free year's membership to any members having never been a MAFCA member before. This is a full membership which includes the finest magazine in the hobby, *The Restorer* as well as free digital version.

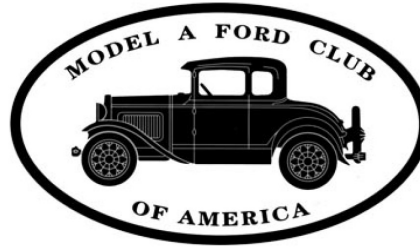

Free USA Membership Application
2018

Please Print

Name: _____

Spouse: _____

Address: _____

Country: _____

City, State/Province: _____

Telephone: _____

Zip Code: _____

Email: _____

I give MAFCA permission to publish my phone number in future membership rosters.

Circle One
Yes No

Optional Initiation Package \$11.00
Plus Shipping Charge

- One Back Issue of *The Restorer*
- One Lapel Pin
- One MAFCA Window Decal
- One Name Badge

Additional Items Of Interest
Plus Shipping Charge

- Denim Baseball Cap...\$15.00
- Spill Proof Travel Mug...\$10.00
- MAFCA Afghan...\$39.00
- Model A Bank...\$25.00

| Item Description | Quantity | Unit Price | Total |
|---|----------|------------|-------|
| 2018USA MAFCA Membership Online Edition | 1 | \$0.00 | 0.00 |
| | | | |
| | | | |
| Add digital Restorer Magazine (must provide email address) | | \$5.00 | |
| Mechanics Handbook Vol. 1 by Les Andrews | | 38.00 | |
| Coupe Book + Polo Shirt Circle Size S M L XL | | 45.00 | |
| Shipping Charges...Up to \$10.00=\$5.75 / \$10.01-\$23=\$9.85 / \$23.01-\$50.00=\$11.95 / 50.01-\$100=\$14.25 | | | |
| Total Purchase | | | |

Visit mafca.com to view our entire store

Requirements For Free Membership

- Only families never having held membership in MAFCA may apply for free membership
- Free membership includes *The Restorer* magazine from the time the application is received by the office. Past issues may be purchased at the regular price depending on availability.

Return Free Membership Form To MAFCA 250 So. Cypress, La Habra, CA 90631-5515
Questions: 562-697-2712

Upcoming Tours and Activities Calendar



Apr 7 (Sat) First Saturday Breakfast BS Session ~ 8AM at The Katella Grill, 1325 W Katella Ave, Orange

Apr 8-10 CCRG in Cambria hosted by Cuesta Cankers, San Luis Obispo; 805-927-4200



Apr 12 (Thu) General Meeting will be at 7:30PM. CHOC Hospital Complex, 455 South Main Street, Orange. Guests are always welcome. Board meeting at 6PM

Orange. Guests are always welcome. Board meeting at 6PM



Apr 14 (Sat) Technical seminar on safety checks at Richard Parrish's home, 909 S. Hacienda Place, Anaheim, 714-393-8582



Apr 22 (Sun) PAN-CAKE BREAKFAST, 8am-11am at Hart Park, Orange. We hope you will all be able to attend.



Apr 26 (Thu) Fourth Thursday Breakfast at Black Bear Diner, 3355

S Bristol St, Santa Ana at 8:30AM; for info contact Terry Collings at 714-970-7194



May 5 (Sat) First Saturday Breakfast BS Session ~ 8AM at The Katella Grill, 1325 W Katella Ave, Orange

May 5 (Sat) MAFCA board meeting, La Habra



May 10 (Thu) General Meeting will be at 7:30PM. Guests are always welcome. Board meeting at 6PM

ing at 6PM

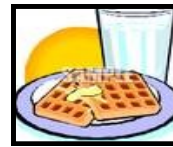

May 24 (Thu) Fourth Thursday Breakfast location to be determined. For info contact

Terry Collings at 714-970-7194

Jun 10 (Sun) Henry Ford Picnic, Heritage Park, Santa Fe Springs

Jun 24-29 MAFCA National Convention, Reno, NV; sign up info ncrgmafca.com/2018mafcaConvention/2018index.html

Jun 24-Jul 1 MARC National Meet, Branson, Missouri

Jun 29 (Sat) MAFCA board meeting, Sparks, NV

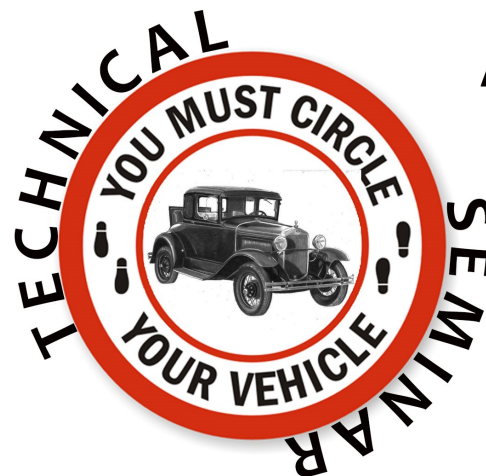

April 14th

SAFETY CHECK

Parrish's Home
909 S. Hacienda Pl
Anaheim
714-393-8582

Swap Meets/Car Shows

April 8 (Sun) Long Beach Hi-Performance Swap Meet at Veterans Memorial Stadium, 5000 Lew Davis, Long Beach, 6am-1pm

Apr 13-14 Bakersfield Swap Meet, Kern County Fairgrounds, 1142 South P St, Ming St. offramp.

Apr 15 (Sun) Pomona Swap Meet & Classic Car Show, Pomona Fairplex, Fairplex Drive and McKinley Ave, Pomona, enter at Gate 17. 5am-2pm

Apr 15 (Sun) 33rd Annual Fabulous Fords Forever Car Show, Knott's Berry Farm, 8039 Beach Blvd., Buena Park, 10am-3pm, Free to spectators

May 5 (Sat) Edelbrook Car Show, Torrance

May 12 (Sat) K-9 Benefits Car Show, Long Beach

May 12 (Sat) Culver Car Show, Culver

May 12 (Sat) Antique Nationals Auto Club Dragway, 9300 Cherry Ave, Fontana, 8am

May 19 (Sat) Bringing Back the Past Car Show at Good Shephard Lutheran Church, 13200 Columbia Way, Downey 90242, 9am-2pm, free admission, downeyshephard.org

Jun 1-2 Friends of Steve McQueen Car Show, Boys Republic Campus, Chino Hills

SAFETY BULLETIN NO. 127A

POST ON BULLETIN BOARD

EXTRA COPIES ON REQUEST



**DON'T JUMP THE
"GET-READY" SIGNAL**

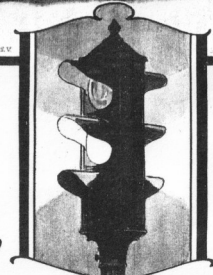

Contributed by Don Johnson. Many thanks. Editor



KEMPER INSURANCE FIRM LICENSED 2-33 10M

PRINTED IN U. S. A.

"L.M.C." ILLUSTRATION COPYRIGHT, 1933

ISSUED BY SAFETY ENGINEERING DEPARTMENT

LUMBERMENS MUTUAL CASUALTY COMPANY

JAMES S. KEMPER, PRESIDENT

Join us for good food
and company

Fourth Thursday
Breakfast Bunch

April 26th at 8:30 a.m.

BLACK BEAR DINER

3355 S Bristol Ave
Santa Ana 92704
657-600-9040

Info: Terry Collings
714-970-7194

If you have
not renewed
your club
membership,
in addition to
not being
included in
the roster, you
will not be
eligible for
the monthly
April roster



2017 BOARD MEMBERS

President – Jim Runyon
714-527-1829/jamesfrunyon@aol.com
VP/Activities – Richard Parrish
714-393-8582/parrich1937@gmail.com
Secretary – Norm Kredit
714-635-3335/leorakredit@yahoo.com
Treasurer – Marilyn Singer Hawkins
714-730-4026/jmsinger@pacbell.net
Technical – Dennis Kliesen
949-466-7475/drkliesen@gmail.com
Editor – Tissy Smith-Hatcher
714-546-8554/tismith@cookseylaw.com
Immediate Past President – Don Ratzlaff
714-529-5062/wadedon@pacbell.net

COMMITTEES

ACCC Representative – David Knapp
(949) 243-5210/david-knapp@cox.net
Breakfast Committee – Terry Collings
714-970-7194/mtcollings@sbcglobal.net
Club Greeter – Doris Marshall
310-378-5061/dandd51@gmail.com
Election Chairperson – Joe Goff
949-768-4627/joe@abt-tax.com
Historian & Librarian – Steve Pavich
714-963-2633/spavich@socal.rr.com
Membership Chairperson – Scott Limbrock
948-981-8776/sbl.frisco@gmail.com
Merchandise Director – Cathy O'Brien
714-777-0771/yjgsrden@aol.com
Pancake Breakfast Setup & Coordination –
Frank Reese, 714-970-6262/Rfrust34@
yahoo.com and Don Ratzlaff, 714-529-
5062/wadedon@pacbell.net
Raffle – Ed Cote
714-542-6161/patricia.cote@att.net
Refreshments – Carolyn Ratzlaff
714-529-5062, dcratzy@gmail.com and
Dianne Runyon 714-390-1528/
jamesfrunyon@aol.com
Regional Representative, SCRG -
Carolyn Ratzlaff, 714-529-5062,
dcratzy@gmail.com
Sunshine & Sorrow – Pam Heiland
714-417-3111/colapam@sbcglobal.net
Web Master – Chris Enright

Please Note: Some information contained in our newsletter has been reprinted from other newsletters; we thank and acknowledge them.

General Meeting Minutes**OCAFC General Meeting****Thursday, March 8, 2018****Wade Education Center at CHOC**

President Jim Runyon called the meeting to order.

Mrs. Cote led everyone in the Pledge of Allegiance.

The “Hello Everybody!” was well done by the one and only Doris Marshall and was accompanied by some humor from our Treasurer, Marilyn Hawkins.

Jim Runyon called everyone’s attention to three special guests. They were Randy Gross and Mark and Sue Leder. Randy has helped many members throughout So. California and MAFCA with parts and advice. Mark and Sue (just visiting) love to tour with the Twin Cities Model A Ford Club, a Minnesota chapter, and Mark edits its newsletter. Sue enjoys touring in her 160A, 1931 Slant Window Fordor. (See page 25 for article and picture of them in the March/ April 2018 Restorer)

The minutes of February 8, 2019 General Meeting were moved, supported, and passed.

Treasurer, Marilyn Hawkins, reported on our finances as of February 28, 2018. The deadline for paying dues for 2018 is March 28. The new directory will be printed soon.

A tour on the calendar for March 17 is the San Antonio Winery. This is a surface street tour for non-freeway drivers. This tour includes lunch at the winery. The tour and lunch are excellent. So put your savings into your gas tank when you get home. “Thank You!” to Richard Parrish our tour leader. Meet at Panera Bread in Brea at the 57 freeway, exit Imperial Hwy. shopping center at 8:30 A.M.

The Mt. Baldy tour is still scheduled for March 29 and it will be taking off from the same Panera Bread in Brea. Meet at 8:30 A.M. for a departure at 9:00 A.M. Lunch will be at the lodge. This tour is pending weather conditions on the ridge road up the mountain. Don Ratzlaff will be the “A” leader. (714.529.5062) Watch for e-mail confirmation.

Technical Advisor Dennis Kliesen has arranged with Richard Parrish to have a seminar on “Safety Checks” on the Model A. Richard has a lift which can help everyone see linkages and adjustments that wear. Richard’s home is 909 S. Hacienda Place, Anaheim, CA 92804. Phone: 714.393.8582

Sunshine and Sorrow Pam Heiland informed us of special members on the high roads and low roads of life. Larry Boef, a member since 1963, passed away recently. His son Trent shared that a “Celebration of Life” was held for him. He had been a very active member. Joe Goff has improved from earlier esophagus trouble so guess who was in the refreshment line. Restoration is a wonderful word.

Special Event Frank Reese updated everyone on the Pancake Breakfast planning. He still needs more items for the raffle. He is encouraging members to talk to retailers for donations of items or gift coupons. He reported a change in the cost of the raffle tickets to encourage more sales and ease at making change. Attendees can buy 6 tickets for \$5.00 or 30 tickets for \$20.00. Sign-up sheets are at the front for helping at (Cont’d on Page 10)

**NEW MEMBERS
CHANGES
CORRECTIONS**

Ratzlaff, Donald & Carolyn, Carolyn's email: dcratzy@gmail.com, 1929
55-A Tudor - Driver

Gaynor, Jeremy & Susan, Jeremy's cell: 714-597-5897

Schmidt, Don & Colleen, Colleen's cell: 714-396-8824

Schwing, Mark & Eileen, Mark's cell: 714-272-4378; Eileen's cell: 714-267-9837

The New Ford Roadster

A great car to drive because of its smart style and alert, capable performance. Speeding along the broad highway at fifty-five to sixty-five miles an hour or parked proudly before your door, the new Ford Roadster impresses with its flowing grace of line and contour. Colors are rich and attractive. The beauty of the straight, sweeping lines is height-

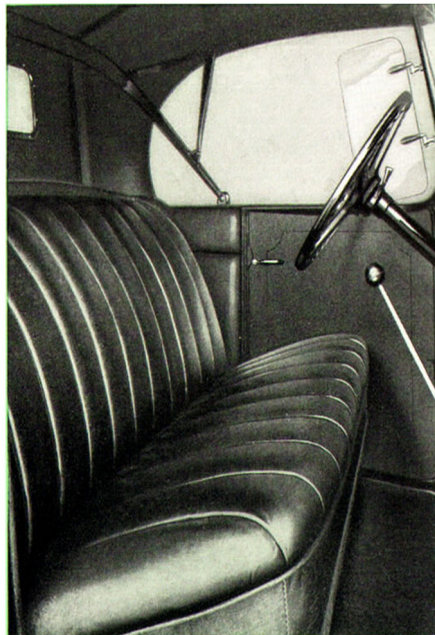

ened when the Triplex shatter-proof windshield is folded flat below eye level.

The wide, roomy seat accommodates two persons in complete comfort and there is plenty of room for a third person in an emergency. The

substantial top, which can be operated quickly and easily, folds very flat when not in use. There is a large luggage space beneath the rear deck, or if desired, a rumble seat to accommodate two additional passengers may be installed inexpensively.

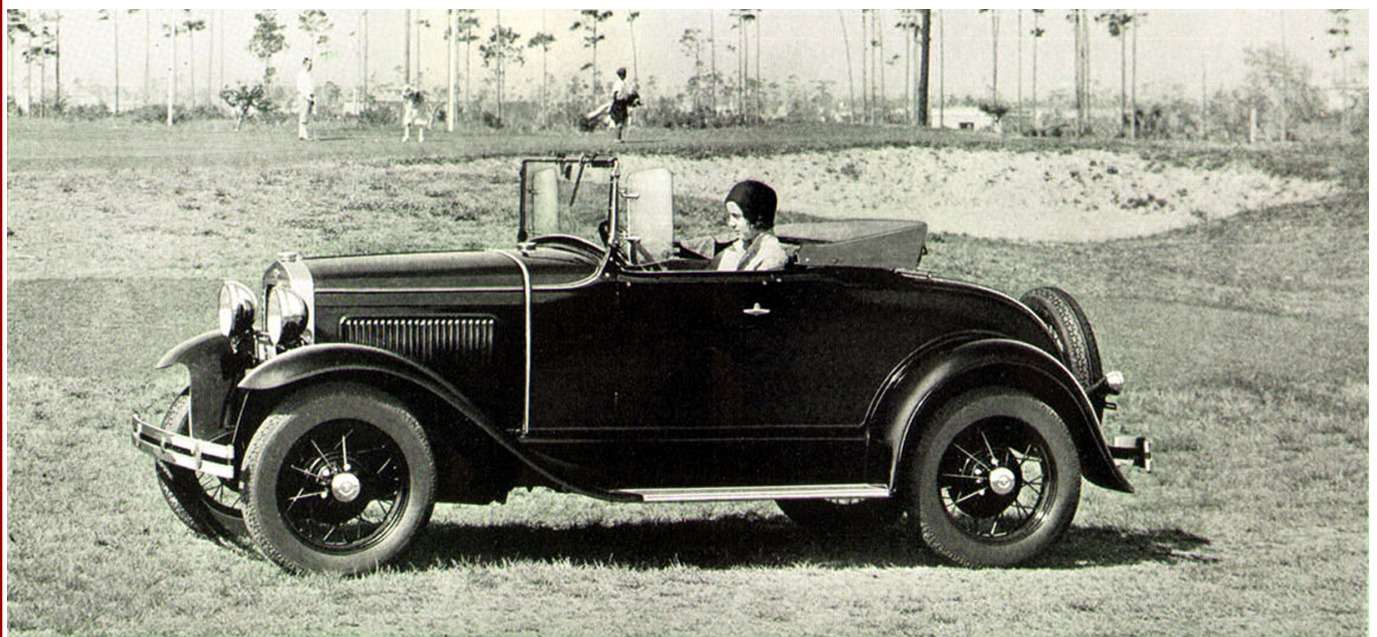
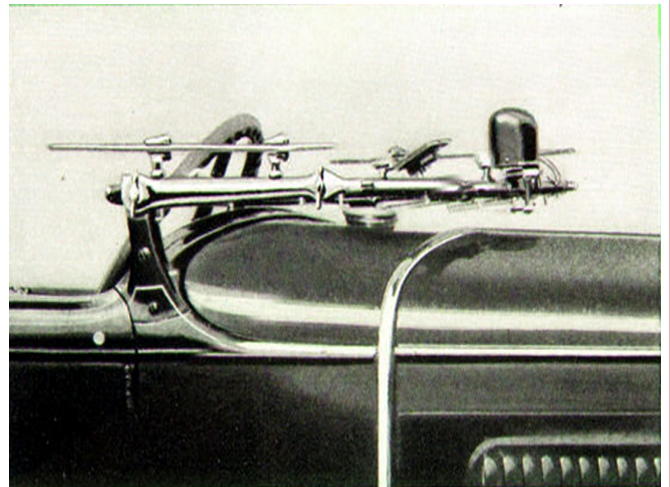

What You Missed

By: Richard Parrish

The San Antonio Winery was an on again off again situation with the storm of the year predicted. I was getting texts and phone calls as late as 10:30 PM Friday evening.

I flatly stated, "St Patrick wouldn't allow it to rain on our tour on his day". The tour was on.

A bright and sunny day greeted us that day. One member drove a DeSoto, 6 others drove Model A's and 3 or 4 more drove modern cars. The tour, as usual produced absolutely no problems and we were greeted at the winery with a complementary sample of sherry, I was especially happy to see long time friends and members Joe and Penny Recker on the tour, the 1st one in decades.

The tour of the winery's inner workings was interesting. It's quite an experience to stand in the middle of thousands of gallons of wine in huge tanks and barrels. Lunch was varied and delicious. President Jim Runyan joined us just as lunch was breaking up in his roadster pickup Alice.

Contrary to my "no freeway" promise, the trip home split and headed our separate directions with the bulk of us taking, what else, the 5 freeway at a spiritedly pace led by a variety of volunteer leaders with me following. Thanks St. Pat for a beautiful day.



BUILD A DISTRIBUTOR WORKSTAND

In the process of rebuilding several Model A distributors, I have developed a workstand which has proven to be very helpful. The distributor casting (with the upper shaft in place or removed) can be mounted at a convenient work height and be held securely without the use of a bench vise. The stand consists of an upright portion (3" square) with a 1" hole drilled vertically to a depth of approximately 4". A second and smaller hole is drilled in the top of the upright to accept the index pin on the casting. When in place on the stand, the distributor is held securely and will not turn during restoration. A base is secured with a wood screw and glue as well as two supports for additional strength. The whole project can be constructed of scrap wood, a few screws and wood glue in less than an hour. It may not revolutionize the hobby, but it does make this job a lot more convenient and protects that metal casting!

Distributor Workstand

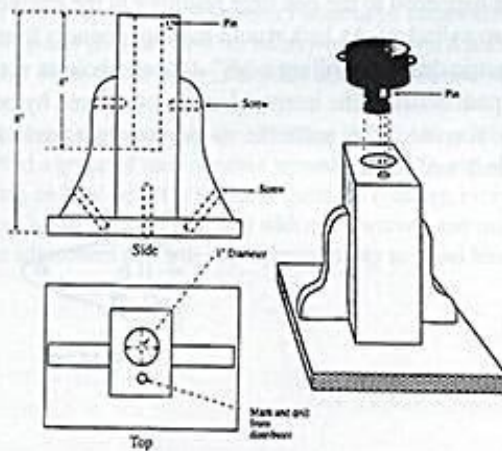

Submitted by Donald R. Geddis, Summit, New Jersey

Deadline for submissions for the next **Distributor** is **April 25, 2018**
 Submit all articles and ads to tismith@cookseylaw.com or mail to P.O. Box 10595, Santa Ana, CA 92711



MAFCA's Blue Oval Program

This New program rewards each MAFCA member for referring a new member. It features a window sticker that you can proudly display on your Model A Ford, a letter of appreciation for your efforts and one entry for each new member you refer into a special drawing for a \$50 gift certificate from MAFCA's store. Drawings are held just prior to the printing of each **Restorer** magazine.

The Reminiscences of Mr. Harold Hicks

(Part 1)

... I was taken off aircraft work for a while to help develop the Model A engine. We knew at the time that Henry Ford was working with Sheldrick on the design of a new engine, that no one knew too much about it. Although we were in one big room, things were held quite confidential. Due to the strict department that everyone pursued in the Company, you didn't wander around out of your place of business too much to find out what the other fellow was doing, you paid strict attention to your own job.

In April, 1927, I was called down to the north end of the big room at the dynamometer section, there was Sorensen, Martin, and Edsel Ford. They showed me an engine that was running on the block. It looked something like the Model T. At least, it had four cylinders. On it they had a vaporizer which was used to distribute the fuel to the various cylinders.

Sorensen did most of the talking. He said, "Well, Hicks, we've got here an engine which is 203 cubic inches." (the Model T was 176, so it was a larger engine than the Model T.) He said, "It is only developing 22 horsepower, you have had pretty good success in developing, power out of engines. If we should give you charge of the development, how much could you get up?"

Well, I took the slide rule, that I always carried, out of my pocket and did a few calculations. I said, "I think I can get you 40 horsepower out of this engine".

All three of them drew long breaths at that time because they were only getting 22, and they were really in quite a predicament. Sorensen said something then that he probably never remembered fifteen minutes later. He said, "Well, Hicks, you've never amounted to much in the Ford Motor Company. Oh, you got the aircraft job, but you've never really been a big shot. How long will it take you to get it?"

I said, "Well, in about three weeks."

He said, "If you can get us 40 horsepower in three weeks, I'll make you the biggest man in the Ford Motor Company."

I could tell that Edsel, although he was anxious to get the 40 horsepower, did not entirely approve of what Sorensen had said.

At any rate, I started in. Without saying anything to any one because it was more or less a secret, and using Carl Schultz to draw up a manifold, we got our first Y-type manifold.

I had used, in calculating the manifolds, certain principles that I had obtained from Colonel Hail way back on the Liberty engine. We got the manifold out, as I remember, in about seven days, working day and night to get the casting made and so forth. Then I went to my friend Howard Menwering who was in the Zenith Carburetor Company and got from him a carburetor to put on the job. (Article continued in the May publication.)

The preceding is an excerpt from "The Reminiscences of Mr. Harold Hicks", from the Owen W. Bombard interviews series, 1951-1961 Accession 65, interview conducted: July 1952 Transcript digitized by staff of Benson Ford Research Center: November 2011

Copyright: Copyright has been transferred to The Henry Ford by the donor, and is made available through a "Creative Commons License BY-NC-ND,"



MODEL A
Roster Raffle

CURRENT JACKPOT 20 **DOLLARS**

If the roster jackpot grows to \$100, and the name pulled is not at the meeting, a second name will be pulled; should it get to \$200, up to 4 names may be called each month until a winner is in attendance.

Leaking Cork Seal

**By: Dennis Kliesen
Technical Director**

I was reading through the articles in some of the old Restorer magazines and stumbled onto an issue in 1993 where they had encountered a leaking cork seal. The author reported the cork gaskets used at the time were of a poor quality being porous and would let the gas filter through them. The author reported he was able to fix the leaking problem by using adhesive cement, blue or clear silicone, to hold the screen in place and then use the silicone on all the surfaces of the cork gasket. This might be ok for an emergency roadside fix, but with the ethanol gas of today that is a blend of gasoline and alcohol I'm not sure how well the silicone sealant would work.

Recently I was helping a club member, Frank Mowrer, do some work on his car and we took his glass sediment bowl off to clean it out. The screen was removed and Frank replaced the neoprene seal. The neoprene gasket that while deteriorated, was not leaking. We installed a new neoprene gasket that was a perfect fit and it did not leak. We were able to clean the screen that had very little debris. The screen can be difficult to reinstall on the housing. There is a recess in the housing to hold the screen in place that can be a little tough to get in place, but the recess in the housing will hold the screen and a cement should not be necessary.

Perhaps they didn't have neoprene seals back in 1993, both are available today with the neoprene being about 3 times the cost of a cork gasket, less than \$3 each. My recommendation, keep an extra neoprene seal for future use and leave out the silicone sealant.

What Do You Think?

There is quite a group of members attending the CCRG tour to Cambria. However, those taking Model A's are trailering them and others are driving their modern iron, so there is no organized tour as such.

There is, however, an alternate event in place of a tour in the planning stage, hopefully, this month. How does a night at the Cinema including a pot luck sound? Several classic movies are under consideration for the evening and if successful, we can look forward to repeat evenings of Summer fun and dining .

Richard Parrish



Many of you remember former club members Richard and Velma Riggs. Their daughter-in-law, Stephanie Riggs, has reached out to the club to see if members are interested in participating in a Rockabilly Car Show at Freedom Village, 23442 El Toro Rd, Lake Forest 92630 on Thursday, June 7th, from 11:30am-1:00pm. Stephanie Riggs is the Marketing Director at the Freedom Village. Their plan is to invite their residents and guest to attend the car show. The residents will select a 1st, 2nd and 3rd place winners. Prizes include cash and gift cards. A delicious lunch served to all attendees. There are limited spots, so let Stephanie know quickly at 949-340-8101 or sriggs@freedomvillage.org



OCMAFC thanks you
for your continued support

**Orange County
Ronald
McDonald
House**

RONALD MCDONALD
HOUSE CHARITIES
SOUTHERN CALIFORNIA



Q: What car was reportedly designed on the back of a Northwest Airlines airsickness bag and released on April Fool's Day, 1970?

A: 1970 Gremlin, (AMC)

Q : Who opened the first drive-in gas station?

A: Gulf opened up the first station in Pittsburgh in 1913.

Q: What city was the first to use parking meters?

A: Oklahoma City, on July 16, 1935.

Q: Where was the first drive-in restaurant?

A: Royce Hailey's Pig Stand opened in Dallas in 1921.

Q: True or False? The 1953 Corvette came in white, red and black.

A: False. The 1953 'Vett's were available in one color, Polo White.

Q: What was Ford's answer to the Chevy Corvette, and other legal street racers of the 1960's?

A: Carroll Shelby's Mustang GT350.

Q: What was the first car fitted with an alternator, rather than a direct current dynamo?

A: The 1960 Plymouth Valiant

Q: What was the first car fitted with a replaceable cartridge oil filter?

A: The 1924 Chrysler.

Q: What was the first car to be offered with a "perpetual guarantee"?

A: The 1904 Acme, from Reading, PA. Perpetuity was disturbing in this case, as Acme closed down in 1911.

Q: What American luxury automaker began by making cages for birds and squirrels?

A: The George N. Pierce Co of Buffalo, who made the Pierce Arrow, also made iceboxes.

(Cont'd from Page 5) various times and tasks that make this a great event. (April 22 is my birthday so give it a shot for me... AND the club.) CALL **Steve Pavich** to pull a parking shift. **714.322.7561**. Call **Richard Bolls** for kitchen, cooking or clean-up help. **714.403.0111** Call Frank for all other help or info.

The annual Fabulous Fords Forever show featuring all Ford models and years will be at Knott's Berry Farm the week before on April 15. Frank Reese is part of the planning group for this. Talk to Frank about helping or displaying your Model A as one of the designated Milestone Cars. (90 years old, not Frank, but the 1928 models.) Frank Reese: 714.348.2507 This will work up your appetite for the Pancake Breakfast.

Extra Information from Gary and Marilyn Chambers is that they can arrange embroidery of the Model A Ford or club logo on your jacket, cap, or shirt through their contacts. The company does beautiful work. Call Gary or Marilyn at 714.328.5219.

Linda Tom donated a batch of key rings to the club.

Don won the "Hard Luck" trophy with his story of a tank full of dirty gas.

"Thank You!" to Bev Marsh and Joanie Harris for the evening refreshments.

Special Note: Kathie McCall informed everyone attending that they need a green 4 hour parking pass to exit without paying. Pick them up from her before you leave. This is a new policy for the parking facility. At the exit gate, pass them your green card and parking ticket or your wallet.

Membership Drawing of \$120 was won by Frank Mowrer. The next drawing will be for \$20. Linda Tom won the Attendance Drawing. Congratulations to both.

Business cards for the OCMAFC are now available to give to those you know and people you meet who may have an interest in joining, so pick some up from Bev Marsh after the meeting.

Auction of donated items: one early club jacket with original club badge, orange in color for \$2.00. Also a motor mount base donated by Bruce Macintosh auctioned off for \$1.00. Ed Cote auctioneer par excellence.

Jerry and Cathy O'Brien are minding the club store. The new shirts are in. Make sure you pick one up for the Pancake Breakfast. The picture of the front of the Model A, which Jerry and Diane Gaughen's own and provided, should always be on your chest. Remember that Jerry and Cathy are retiring and need someone to take their place.

Norm Kredit, Secretary

IN MEMORIAM Larry Boef

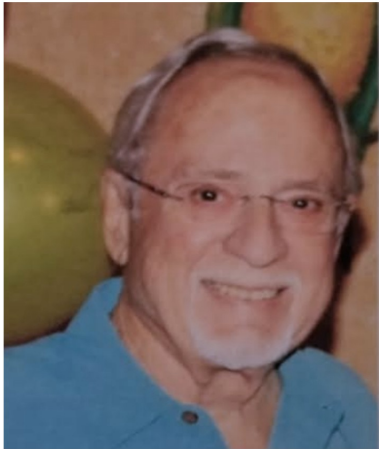

Larry was a life member of our club. He was President in 1966 and 1971, along with being Vice President. He never missed an opportunity to join a tour or campout. He had numerous Model A's, one of which finished First place at the National Convention at the Queen Mary in the 70's. He hosted many parties and seminars at his family home.

Funny story. Some club members were cruising in downtown Idyllwild in a double A truck; they spotted actor Fred MacMurray and Larry kidnapped him to cruise with us. Soon, Fred was drinking beer and enjoying himself.

Larry will be missed for his contributions and friendships with club members, but more importantly, by his loving family.

No memorial service is scheduled at this time.

Thank you to his proud son, Trent, for providing us with this info.

SUNSHINE & SORROW

By Pam Heiland

A get well card was sent to Fran Earhart who suffered a bad fall. I understand she is doing okay now. Also, cards of encouragement were sent to Don Schmidt, Tina Mowrer and Mel Collings. They have all had health challenges over the past several months and get well cards were sent, but I just figured they could all use a little encouragement too.



I hope everyone has managed to avoid the flu, etc. Stay healthy everyone...the pancake breakfast is drawing near!

Thought for the day:

"Success is when you look back at your life and the memories make you smile!"



ORANGE COUNTY
MODEL A FORD
CLUB

Post Office Box 10595
Santa Ana, CA 92711

E-mail: info@ocmafc.org

Next General Meeting

7:30 PM

[Second Thursday of every month]

Next Meeting April 12, 2018

CHOC Hospital Complex

455 South Main Street, Orange, CA

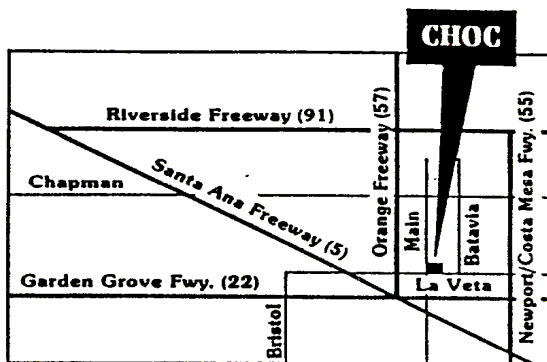

From Main Street, turn east on to Providence Ave. and immediately on your right, enter the structure and park on the second level. Meetings are held in Building 2 in the Wade Education Center-2nd Floor. Access meeting room through the double door entry off the 2nd Floor parking structure

We are on the Web!
www.ocmafc.org

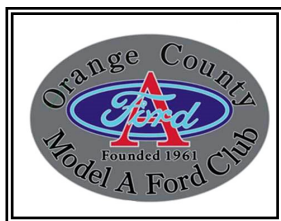

Return Address:
Post Office Box 10595
Santa Ana, CA 92711

To:

Empty rounded rectangular box for recipient address.

First Class Mail